

TECHLINE PART SHEET

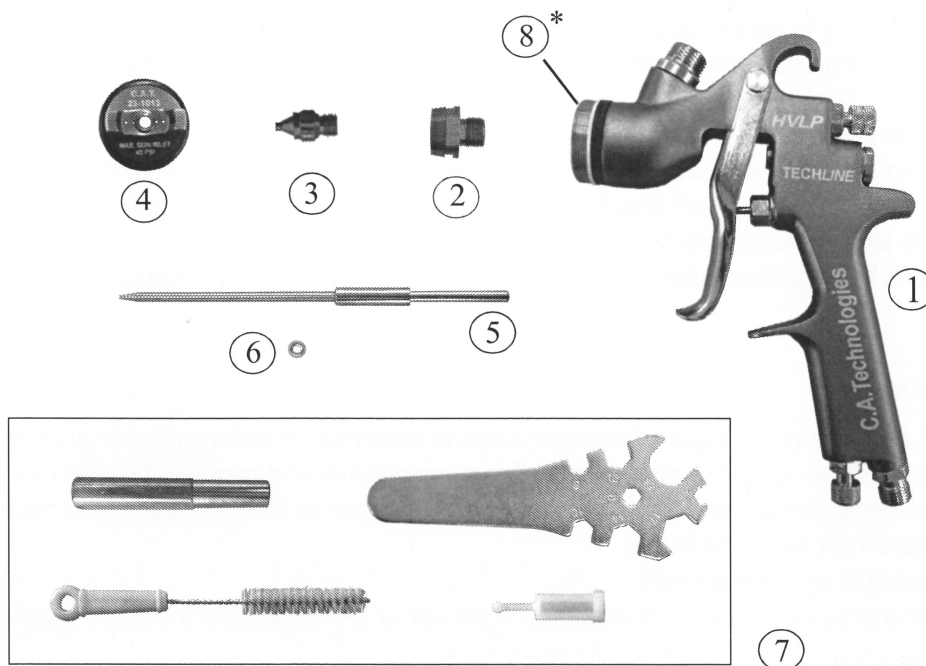

PART #	DESCRIPTION	PART #	DESCRIPTION
1 60-1130	BODY ASSEMBLY	5 SEE BELOW	NEEDLE
2 33-1201	NOZZLE BODY	6 61-1014	PACKING
3 SEE BELOW	ORIFICE	7 10-111	TOOL KIT Includes: Gun w rench, filter, needle packing w rench, and brush
4 SEE BELOW	AIRCAP		

NOZZLE NEEDLE CHART

ORIFICE SIZE	AIR CAP	*MAX GUN INLET PRESS. FOR HVLP	ORIFICE (TIP)	NEEDLE
1.3	23-1013	45	33-0213	40-P1313
1.4	23-1014	45	33-0214	40-P1314
1.5	23-1015	45	33-0215	40-P1315
1.7	23-1017	45	33-0217	40-P1317
1.9	23-1019	45	33-0219	40-P1319
2.2	23-1022	45	33-0222	40-P1322

*Air cap test gages are available to confirm HVLP compliance.

NOTE*

Do not remove Fluid Nozzle Carrier from gun (#8)

The needle packing nut needs manual adjustment and must be tightened periodically to avoid leaks. Use the packing wrench supplied in 10-111 kit

Operation and Maintenance Instructions for *Techline* Spray Guns

Operation

1. Connect air supply hose at handle of gun (see page 1 for suggested gun inlet pressures).
2. The optional air control valve built into the gun handle can be used to adjust gun inlet pressure.
3. Screw the paint cup onto the gun's gravity feed fluid inlet.
4. Fluid flow can be controlled using the fluid control knob, this restricts flow by limiting needle travel. It is best to control fluid flow by proper selection of fluid orifice size and use the fluid control knob to "fine tune flow rate."
5. Fan width can be adjusted using the fan control knob. Turning the knob clockwise narrows the fan.

Maintenance

IMPORTANT! Routine cleaning and maintenance is essential to insure proper gun operation. Several states prohibit spraying solvent into the atmosphere and require the use of a covered gun cleaner.

1. If a gun cleaner is being used, connect and clean the gun in the gun cleaner according to the manufacturers recommendations.
2. If a gun cleaner is not being used:
First clean the gravity feed cup thoroughly, then spray clean solvent through the gun until clean.

TECHLINE NOZZLE SELECTION CHART		
Material	Orifice Size	T3 HVLP
Filler	1.7	45 PSI @ 13.5 cfm
Primer, Washprimer, Epoxy	1.4-1.7	45 PSI @ 13.5 cfm
Sealer	1.4-1.7	45 PSI @ 13.5 cfm
Single Stage	1.3-1.4	45 PSI @ 13.5 cfm
Basecoat	1.3-1.4	45 PSI @ 13.5 cfm
Clearcoat	1.3-1.4	45 PSI @ 13.5 cfm
High Solids Clears	1.4-1.5	45 PSI @ 13.5 cfm

KITS FOR TECHLINE HVLP GRAVITY GUN				
HVLP KITS	ORIFICE SIZE	AIR CAP	ORIFICE (TIP)	NEEDLE
TK 1010	1	23-1010	33-0210	40-P1310
TK 1013	1.3	23-1013	33-0213	40-P1313
TK 1014	1.4	23-1014	33-0214	40-P1314
TK 1015	1.5	23-1015	33-0215	40-P1315
TK 1017	1.7	23-1017	33-0217	40-P1317
TK 1019	1.9	23-1019	33-0219	40-P1319
TK 1022	2.2	23-1022	33-0222	40-P1322